

Full Circle Financial Services

And

Jindal Intellicom

Offshore Advantage, Delivered On-Shore



FULL CIRCLE
collections

intellicom
CONTACT CENTERS



Business Overview

- Full Circle Financial Services, LLC is a consumer debt collection agency with its main office in Florida and branch location in New Delhi, India. Both locations are licensed for collections in all US states except NV & PR.
 - Full Circle has over 350 FDCPA certified experienced collectors in its New Delhi location currently and growing each month. We collect for leading agencies and debt buyers in the US.
 - Portfolio types - Portfolios in various stages of delinquency including, Pre Charge-Off as well as Post Charge-Off ranging from early to late stage & Out of Stat.
 - We service a large range of products - Bankcards, Retail Charge Cards, Lines of Credit, and Telecom and have demonstrated higher productivity in challenger comparisons with US and other Off-shore collection call centers.
 - Our on-shore AND off-shore IT, Physical & Security Infrastructure has been certified compliant to the rigorous requirements of leading debt buyers and US banks.
-

Business Overview

- Full Circle Collections uses a state of art collections platform called AdvantEdge from Accelerated Data Systems. This platform is accessible from all of Full Circle's locations in the US & India. AdvantEdge has been integrated with 3rd party services and information providers for lettering, payment processing, bankruptcy/ NCOA scrubbing, skip-trace etc and credit rating/scoring accounts.
- You also have the option of having us logged on to your platform. We have expertise in working on and integrating with multiple collections platforms including FACS, Latitude, CUBS and AdvantEdge amongst others.
- Current placement – spots & forward flows included - exceeds \$400 million in face value.

Intellicom USP – Combination of offshore delivery capability, ability to quickly ramp-up, operational excellence, redundant & secure technology architecture and domain knowledge.

Client – Large Collections Agency

Statistics from a recent 4 month period

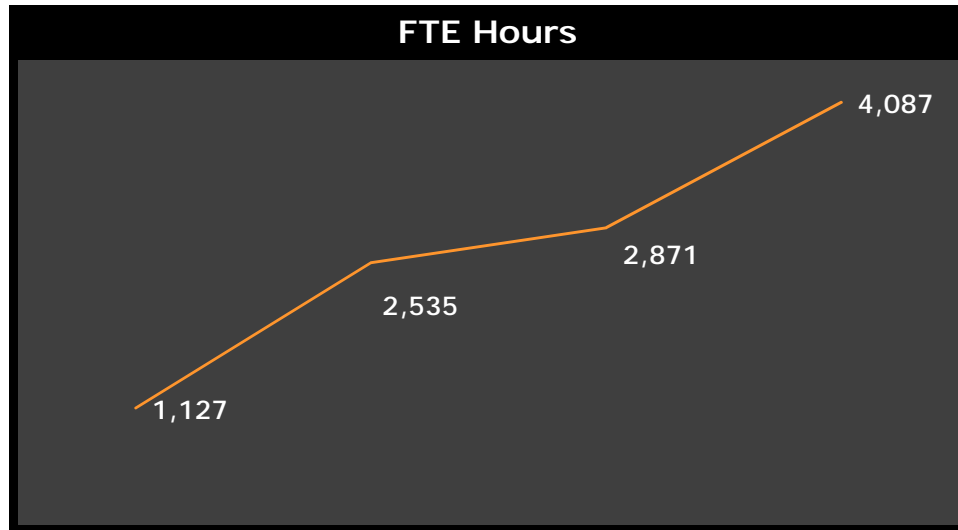
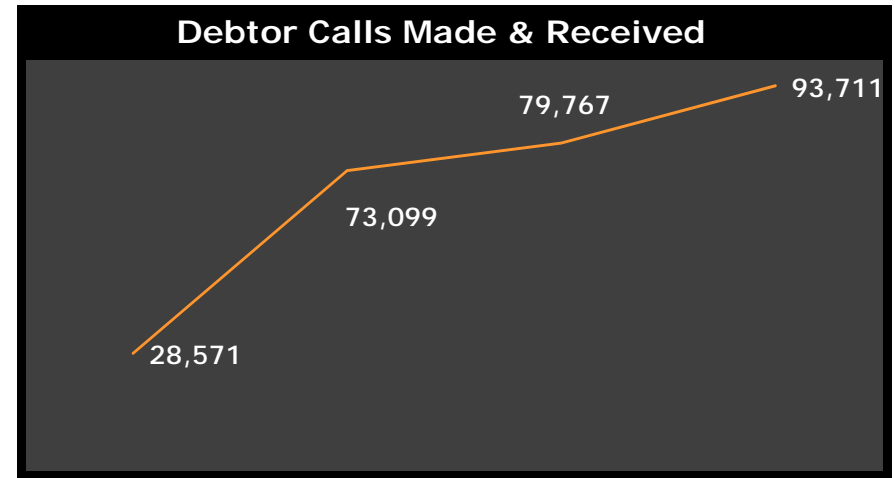
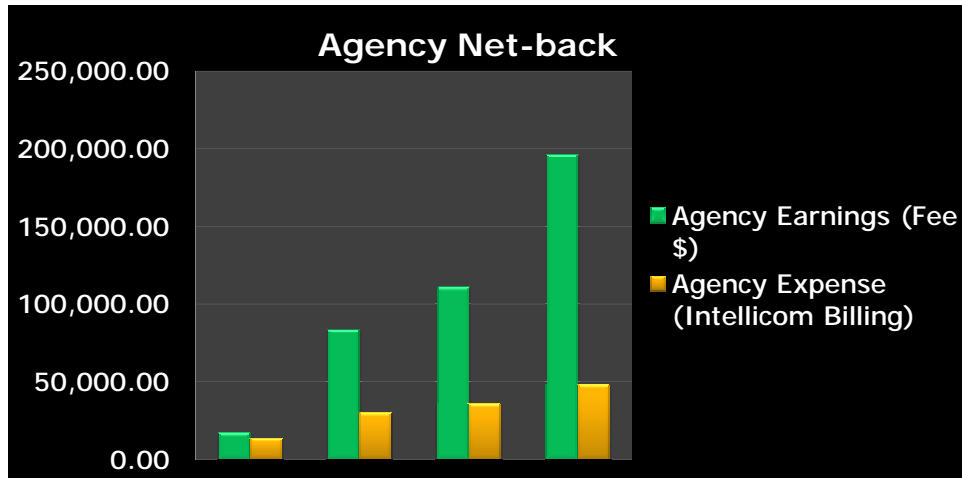

- This Agency sources call center services from suppliers within and outside of the US. Within 4 months of engagement, Intellicom has become the most profitable supplier to this Agency.
- Due to our highly scalable platform, we have been able to grow this engagement by over 400% in a span of approx. 150 days.
- Success of a robust transition model - Client operations at Intellicom are an exact replica of Client's in-house US call center.

Client – Large Debt Buyer

Statistics from a recent quarter

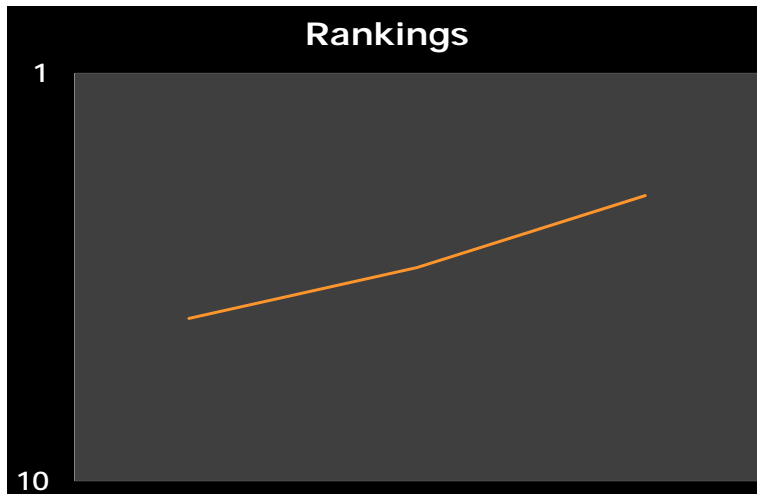
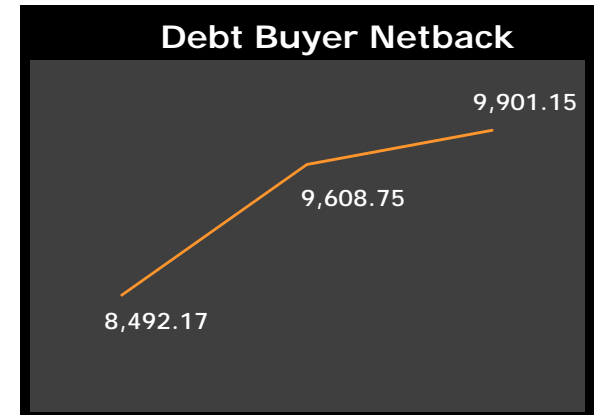
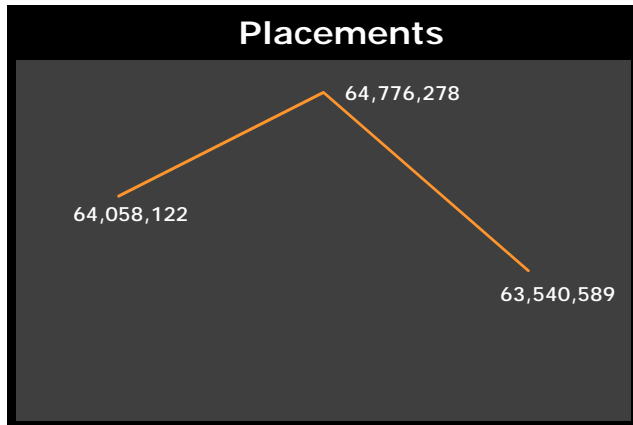

- Client is a large debt buyer across product type portfolios.
- Debt buyer netback = \$ collected – Intellicom fee.
- Though placement volumes dropped, Intellicom was able to increase netback.
- Consolidated ranking position in challenger comparison with other US & offshore call centers.

Corporate Overview

- **Jindal Intellicom and Full Circle Financial Services are part of the \$8.5 Bn Jindal Group.** The Jindal Group is India's 4th largest business house, a multinational corporate with an employee base of over 18,000 and presence in more than 20 countries. The Group's businesses include Metal, Power, Mining, Consulting, Travel, Network Infrastructure and Software Consulting.
 - **Full Circle & Intellicom represents the Jindal Group's strategic focus in Business process Outsourcing.**
 - **Site location & Capacity – Our New Delhi delivery center is located in a 2.5 Acre Campus, in the heart of the city.** We currently have 650 FTE positions operational and floor-space available for an additional 500 positions. Infrastructure is available for an additional 1,000 FTE positions.
 - **New Delhi location benefit:** We are very close to large residential colonies, and the only call center within a 8 mile radius. Since all agents are transported from and to their homes by company cabs, travel time to Intellicom vis-à-vis other centers is an average 45 minutes compared to 120 minutes each way. This coupled with our group brand image makes us the employer of choice.
-

Structure & Strengths



On-shore
presence

Off-shore
advantage

Network & IT Application Infrastructure

- We have deployed **redundant connectivity** through diverse paths – in the domestic and international sector – to the Points Of Presence (PoPs) in Los Angeles, USA and London, UK.
- The connectivity includes Point-to-Point International Private Leased Lines (IPLC) and Multi Protocol Layered Service (MPLS) contracted with leading international carriers offering high level of network up-time and automatic back-up routing.
- Our IT systems are architected for quick and secure connectivity to diverse client applications.
- We have recently adopted the ISO 27001 (formerly BS 7799) set of IT Security standards and is aiming for certification by Q2– 2008.

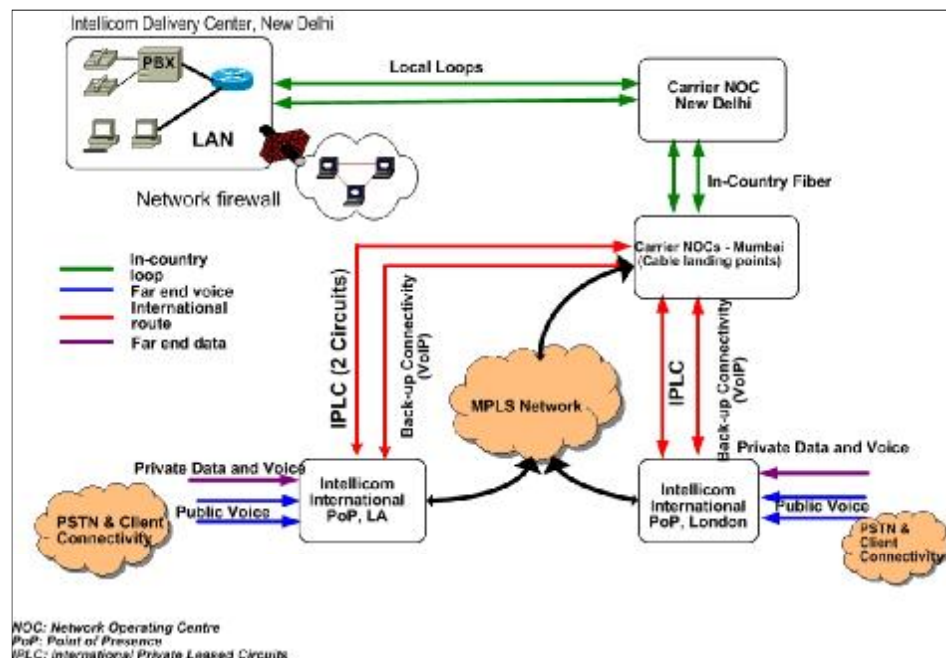
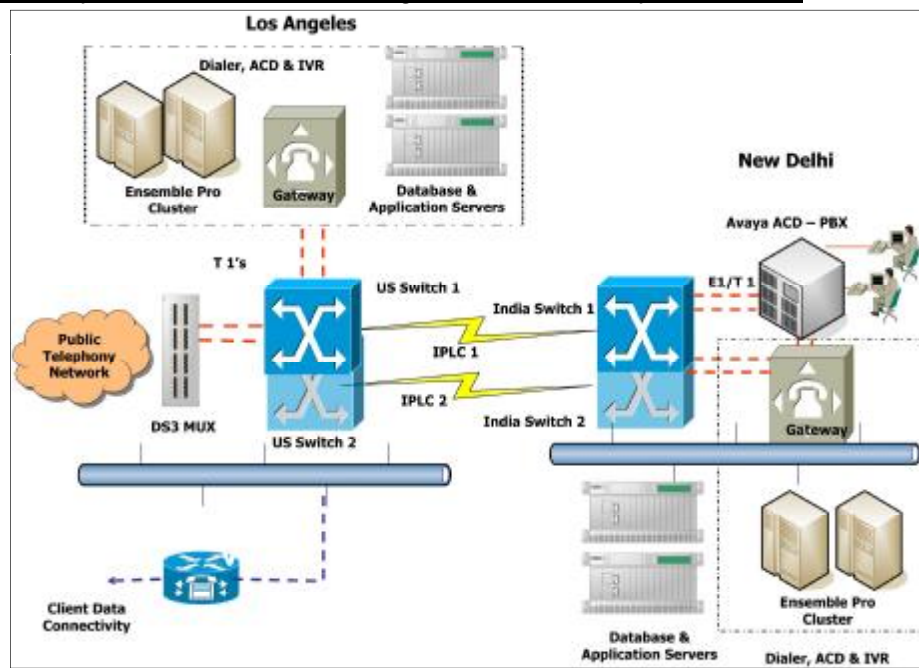

- Our IT group ensures a **very high degree of application availability** through use of a dual set of Dialer, ACD and IVR system - in India & the US - working in a redundant configuration.
- Similar redundancy achieved on the network side with use of dual network switches.
- All IT Applications, Hardware and Telecommunication networks are administered from our in-house **24 X 7 Network Operations Center** in New Delhi.
- Our IT & Physical infrastructure has been **certified compliant to rigorous security specifications** of leading US banks and debt buyers for recoveries.

Advantage Intellicom & Full Circle

- Project execution capabilities - Our Process Transition Team has effectively and efficiently migrated various customer interaction projects offshore and proved its competence. **We have met all client SLA's within 4 to 6 weeks after the initial pilot.**
 - Proven ability to add value – We focus on working with a select few clients so that our experienced and technologically capable team can quickly reach desired SLAs, as well as provide additional value to the client by leveraging our experience.
 - Financially Sound Promoters – Backed by the US \$ 8.5 Billion Jindal Group.
 - **State of the Art Infrastructure, Secure & Scalable, In-house software development team.**
 - Locational advantage and brand identity make us an employer of choice, enabling us to acquire and retain quality staff.
-

Thank You

Manoj Matai

manoj@fullcirclecollections.com

(213) 270 6723

*Look us up at booth 127 at the Financial Services
Collections Conference.*
